

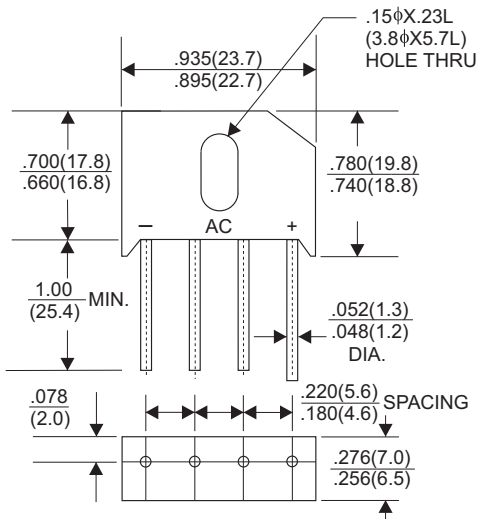

# KBU8A THRU KBU8M

**SINGLE PHASE BRIDGE RECTIFIERS**  
**Reverse Voltage - 50 to 1000 Volts    Forward Current - 8.0 Ampere**

## KBU



Dimensions in inches and (millimeters)

## FEATURES

- \* Glass Passivated Die Construction
- \* Low forward voltage drop
- \* High current capability
- \* High reliability
- \* High surge current capability

## MECHANICAL DATA

- \* Case: Molded plastic
- \* Epoxy: UL 94V-0 rate flame retardant
- \* Lead: Axial leads, solderable per
- \* Polarity: Color band denotes cathode end
- \* Mounting position: Any

## MAXIMUM RATINGS AND ELECTRICAL CHARACTERISTICS

Rating 25°C ambient temperature unless otherwise specified.  
 Single phase half wave, 60Hz, resistive or inductive load.  
 For capacitive load, derate current by 20%.

TYPE NUMBER	KBU8A	KBU8B	KBU8D	KBU8G	KBU8J	KBU8K	KBU8M	UNITS	
Maximum Recurrent Peak Reverse Voltage	50	100	200	400	600	800	1000	V	
Maximum RMS Voltage	35	70	140	280	420	560	700	V	
Maximum DC Blocking Voltage	50	100	200	400	600	800	1000	V	
Maximum Average Forward Rectified Current									
.375"(9.5mm) Lead Length at Tc=50°C								8.0	A
Peak Forward Surge Current, 8.3 ms single half sine-wave superimposed on rated load (JEDEC method)								250	A
Maximum Forward Voltage Drop per Bridge Element at 8.0A D.C.								1.1	V
Maximum DC Reverse Current Ta=25°C								10	μA
at Rated DC Blocking Voltage Ta=100°C								200	μA
Operating Temperature Range, Tj								-65 — +125	°C
Storage Temperature Range, Tstg								-65 — +150	°C

# RATING AND CHARACTERISTIC CURVES (KBU8A THRU KBU8M)

FIG.1-TYPICAL FORWARD CURRENT DERATING CURVE

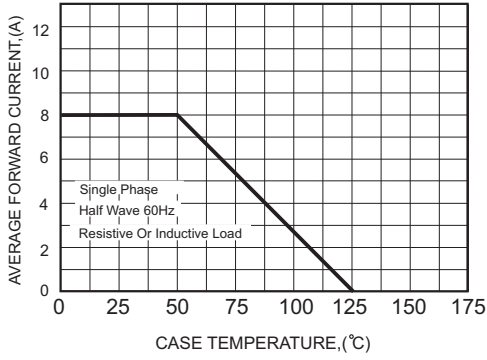

FIG.2-MAXIMUM NON-REPETITIVE FORWARD SURGE CURRENT

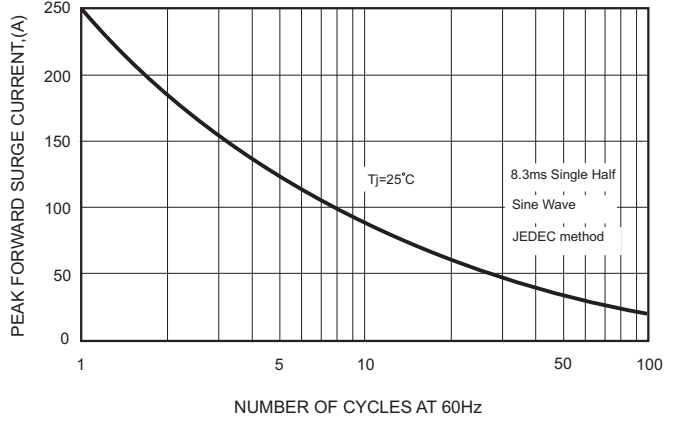

FIG.3-TYPICAL FORWARD CHARACTERISTICS

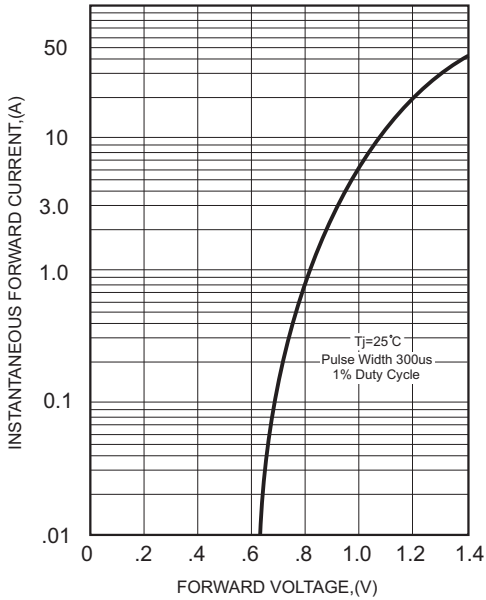

FIG.4-TYPICAL REVERSE CHARACTERISTICS

